

640 30~150mm Continuous Zoom IP Thermal Module VS-SCM61505NR2-D



- 640*512, 12 μ m Uncooled VOx Microbolometer.
- Max. Resolution: 640*512 @ 25fps.
- 30~150mm, 5 \times Continuous Zoom, Auto-focus, fast and accurate focus.
- Support various pseudo-colour switching such as black-hot, white-hot and multiple false colours
- Supports triple streams for different resolutions and frame rates for live preview and stored streams.
- Supports H.265 compression encoding format with higher encoding compression rate.
- Supports tripwire, intrusion, loitering and many other intelligent analysis functions.
- Supports ONVIF, Compatible with VMS and network devices from leading manufacturers.
- Full functions: PTZ control, Alarm, OSD, etc.

Specification

Camera		
Detector	Detector Type	Uncooled VOx Microbolometer
	Pixel Pitch	12 μ m
	Resolution	640 * 512
	Spectral Band	8 ~ 14 μ m
	NETD	\leq 50mk @25°C, F#1.0 (\leq 40mK Option)
Lens	Focal Length	30 ~ 150mm
	Zoom	5 \times
	Aperture	FNo : 0.85 ~ 1.2
	HFOV	14.59° ~ 2.93°
	VFOV	11.69° ~ 2.35°
	Zoom Speed	Approx. 3.0 Sec (Wide ~ Tele)
	Mrad	0.080 ~ 0.400
Video & Audio Network	Compression	H.265/H.264/H.264H/MJPEG
	Resolution	Main Stream : PAL@25fps : 1280*1024 1280*720 640*512 NTSC@25fps : 1280*1024 1280*720 640*512 Sub Stream1 : PAL@25fps : 640*512 352*288 NTSC@25fps : 640*512 352*240 Sub Stream2 : PAL@25fps : 640*512 352*288 NTSC@25fps : 640*512 352*240
	Video Bit Rate	256 ~ 1792 Kb / S
	Audio Compression	AAC / MPEG2-Layer2
	Storage Capabilities	TF card, up to 1Tb
	Network Protocols	ONVIF, HTTP, RTSP, RTP, TCP, UDP
	General Events	Motion Detection, Tamper Detection, Scene Changing, Audio Detection, SD Card, Network, Illegal Access
	IVS	Tripwire, Intrusion, Loitering, etc.
Upgrade	Support	
Noise Reduction	Support	
Palette	Support	
Flip	Support	
FFC Mode	Auto / Manual	
Fire Detection	Support	
Focus Model	Auto/Manual	
Zoom speed	Support	
External Control	2 \times TTL3.3V, Compatible with VISCA and PELCO protocols	

Video Output	Network
Baud Rate	9600
Operating Conditions	-30°C ~ +60°C; 20% ~ 80% RH
Storage Conditions	-40°C ~ +70°C; 20% ~ 95% RH
Weight	3400g
Power Supply	9 ~ 12V DC
Power Consumption	Static: 3.0W; Max: 4.0W
Dimensions (mm)	263*Φ187

DRI Distance ¹		
Effective Distance, human (1.80 m x 0.75 m) ¹	Detection	6250m (20505 ft)
	Recognition	1563m (5127 ft)
	Identification	781m (2562 ft)
Effective Distance, vehicle (4.0 m x 2.30 m) ¹	Detection	19167m (62883 ft)
	Recognition	4792m (15721 ft)
	Identification	2396m (7850 ft)

1. An infrared camera's effective range is what is meant by seeing an object". Defined thresholds, known as Johnson's Criteria, refer to the minimum number of pixels necessary to either detect, recognize, or identify targets captured by scene imagers. The lower limits of detection, recognition, and identification (DRI), according to Johnson criteria are:

Detection: In order to distinguish an object from the background, the image must be covered by 1.5 or more pixels.

Recognition: In order to classify the object (animal, human, vehicle, boat, etc.), the image must have at least 6 pixels across its critical dimension.

Identification: In order to identify the object and describe it in details, the critical dimension must have be least 12 pixels across.

Dimensions (mm)

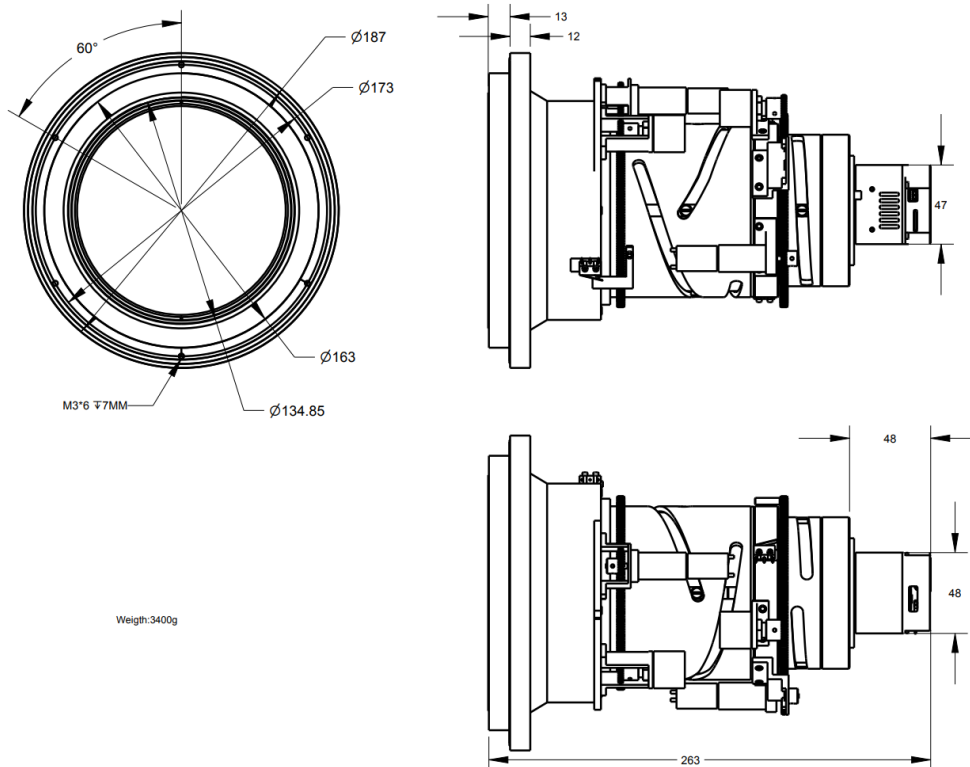

Interface

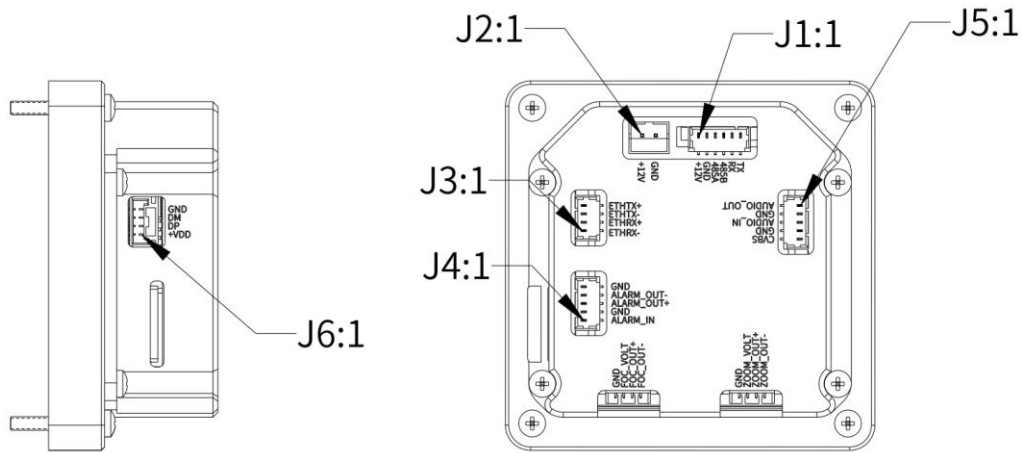

Pin Assignment

Type	Sequence	PIN Name	Instruction
J1_6PIN Power serial port	1	DC_IN	DC power input port, required:DC +9 ~ +12V
	2	GND	Power GND
	3	RXD1	RS485A,Using the Pelco protocol
	4	TXD1	RS485B,Using the Pelco protocol
	5	RXD0	TTL level(3.3V),Camera serial port receives signal,Using the Visca protocol
	6	TXD0	TTL level(3.3V),Camera serial port sends signal,Using the Visca protocol
J2_2PIN Power supply	1	DC_IN	DC power input port, required:DC +9 ~ +12V
	2	GND	Power GND
J3_4PIN Network Interface	1	ETHRX -	Adaptive network port, physical receiving signal (-differential)
	2	ETHRX +	Adaptive network port, physical receiving signal (+differential)
	3	ETHTX -	Adaptive network port, physical receiving signal (-differential)
	4	ETHTX +	Adaptive network port, physical receiving signal (+differential)
J4_5PIN Alarm port	1	Alarm_IN	Alarm_In serial port
	2	GND	Alarm_IN GND
	3	Alarm_OUT+	When there is an alarm output, it is the on state When there is no alarm output, it is the off state (there is no positive/negative polarity distinction, it is only for the convenience of labeling)
	4	Alarm_OUT-	
	5	GND	Alarm_OUT GND
J5_5PIN Audio port	1	AUDIO_OUT	Audio output signal, support LINE OUT output mode
	2	GND	GND
	3	AUDIO_IN	Audio input signal, support LINE IN output mode
	4	GND	GND
	5	CVBS	CVBS Out